

- () Preliminary Specifications
- (V) Final Specifications

Module	5.7 Inch Color TFT-LCD
Model Name	G057QTN01.0

<p>Customer</p> <p>_____</p>	<p>Date</p> <p>_____</p>
<p>Checked & Approved by</p> <p>_____</p>	
<p>Note: This Specification is subject to change without notice.</p>	

<p>Approved by</p> <p>_____</p>	<p>Date</p> <p>_____</p>
<p>LeaDer Feng</p>	<p>2021/6/16</p>
<p>Prepared by</p> <p>_____</p>	
<p>Carol Wong</p>	<p>2021/6/16</p>
<p>Audio-Video Business Unit / AU Optronics corporation</p>	



AUO Display Plus Confidential
AVNET_EU
20220413 19:50:15

AUO Display Plus Confidential
AVNET_EU
20220413 19:50:15

AUO Display Plus Confidential
AVNET_EU
20220413 19:50:15

AUO Display Plus Confidential
AVNET_EU
20220413 19:50:15

ADP Confidential

Contents

1. Operating Precautions	6
2. General Description	7
2.1 Display Characteristics	7
2.2 Optical Characteristics	8
3. Functional Block Diagram.....	13
4. Absolute Maximum Ratings	14
4.1 Absolute Ratings of TFT LCD Module.....	14
4.2 Absolute Ratings of Environment	14
5. Electrical Characteristics.....	15
5.1 TFT LCD Module	15
5.2 Backlight Unit.....	16
6. Signal Characteristic	18
6.1 Pixel Format Image	18
6.2 Scanning Direction	18
6.3 TFT- LCD Interface Signal Description	20
6.4 The Input Data Format	21
6.5 Interface Timing	22
6.6 LED Backlight Unit Interface Signal Description	23
6.7 Power ON/OFF Sequence.....	23
7. Connector & Pin Assignment.....	25
7.1 TFT- LCD Signal (CN1): LCD Connector	25
7.2 LED Backlight Unit (CN2): Backlight Connector	25
7.3 LED Light Bar Input (CN3): Light Bar Connector	26
7.4 Connector Illustration.....	26
8. Reliability Test Criteria	28
9. Mechanical Characteristics	29
10. Label and Packaging	30
10.1 Shipping Label (on the rear side of TFT-LCD display).....	30
10.2 Carton Package.....	30
11 Safety	31
11.1 Sharp Edge Requirements	31
11.2 Materials.....	31
11.3 Capacitors	31
11.4 National Test Lab Requirement	31

Record of Revision

Version and Date	Page	Old description	New Description																																																																																																																																																																																																																															
0.0 2013/7/20	All	First Edition																																																																																																																																																																																																																																
0.1 2013/9/25	6	Brightness, typ 450, min 350	Brightness, typ 500, min 400																																																																																																																																																																																																																															
1.0 2014/1/15	5		Power consumption 1.9W																																																																																																																																																																																																																															
	11		VDD Current and Power <table border="1"> <tr> <td>IDD¹⁾</td> <td>VDD Current¹⁾</td> <td>-²⁾</td> <td>115³⁾</td> <td>130³⁾</td> <td>[mA]⁴⁾</td> <td>All Black Pattern⁵⁾ (VDD=3.3V, at 60Hz)⁶⁾</td> </tr> <tr> <td>Irush¹⁾</td> <td>LCD Inrush Current¹⁾</td> <td>-²⁾</td> <td>-²⁾</td> <td>1.5³⁾</td> <td>[A]⁴⁾</td> <td>Note 1⁷⁾</td> </tr> <tr> <td>PDD¹⁾</td> <td>VDD Power¹⁾</td> <td>-²⁾</td> <td>0.46³⁾</td> <td>0.51³⁾</td> <td>[Watt]⁴⁾</td> <td>All Black Pattern⁵⁾ (VDD=3.3V, at 60Hz)⁶⁾</td> </tr> </table>	IDD ¹⁾	VDD Current ¹⁾	- ²⁾	115 ³⁾	130 ³⁾	[mA] ⁴⁾	All Black Pattern ⁵⁾ (VDD=3.3V, at 60Hz) ⁶⁾	Irush ¹⁾	LCD Inrush Current ¹⁾	- ²⁾	- ²⁾	1.5 ³⁾	[A] ⁴⁾	Note 1 ⁷⁾	PDD ¹⁾	VDD Power ¹⁾	- ²⁾	0.46 ³⁾	0.51 ³⁾	[Watt] ⁴⁾	All Black Pattern ⁵⁾ (VDD=3.3V, at 60Hz) ⁶⁾																																																																																																																																																																																																										
IDD ¹⁾	VDD Current ¹⁾	- ²⁾	115 ³⁾	130 ³⁾	[mA] ⁴⁾	All Black Pattern ⁵⁾ (VDD=3.3V, at 60Hz) ⁶⁾																																																																																																																																																																																																																												
Irush ¹⁾	LCD Inrush Current ¹⁾	- ²⁾	- ²⁾	1.5 ³⁾	[A] ⁴⁾	Note 1 ⁷⁾																																																																																																																																																																																																																												
PDD ¹⁾	VDD Power ¹⁾	- ²⁾	0.46 ³⁾	0.51 ³⁾	[Watt] ⁴⁾	All Black Pattern ⁵⁾ (VDD=3.3V, at 60Hz) ⁶⁾																																																																																																																																																																																																																												
	12	Input voltage for RL/UD <table border="1"> <tr> <td rowspan="2">Input Voltage for RL/UD</td> <td>High¹⁾</td> <td>VIH¹⁾</td> <td>0.7VDD²⁾</td> <td>-³⁾</td> <td>VDD⁴⁾</td> <td>Volt⁵⁾</td> </tr> <tr> <td>Low¹⁾</td> <td>VIL¹⁾</td> <td>0²⁾</td> <td>-³⁾</td> <td>0.3VDD²⁾</td> <td>Volt⁵⁾</td> </tr> </table>	Input Voltage for RL/UD	High ¹⁾	VIH ¹⁾	0.7VDD ²⁾	- ³⁾	VDD ⁴⁾	Volt ⁵⁾	Low ¹⁾	VIL ¹⁾	0 ²⁾	- ³⁾	0.3VDD ²⁾	Volt ⁵⁾	Input voltage for RL/UD <table border="1"> <tr> <td rowspan="2">Input Voltage for RL/UD</td> <td>High¹⁾</td> <td>VIH¹⁾</td> <td>0.7VDD²⁾</td> <td>-³⁾</td> <td>VDD⁴⁾</td> <td>Volt⁵⁾</td> </tr> <tr> <td>Low¹⁾</td> <td>VIL¹⁾</td> <td>0²⁾</td> <td>-³⁾</td> <td>0.2VDD²⁾</td> <td>Volt⁵⁾</td> </tr> </table>	Input Voltage for RL/UD	High ¹⁾	VIH ¹⁾	0.7VDD ²⁾	- ³⁾	VDD ⁴⁾	Volt ⁵⁾	Low ¹⁾	VIL ¹⁾	0 ²⁾	- ³⁾	0.2VDD ²⁾	Volt ⁵⁾																																																																																																																																																																																																					
Input Voltage for RL/UD	High ¹⁾	VIH ¹⁾		0.7VDD ²⁾	- ³⁾	VDD ⁴⁾	Volt ⁵⁾																																																																																																																																																																																																																											
	Low ¹⁾	VIL ¹⁾	0 ²⁾	- ³⁾	0.3VDD ²⁾	Volt ⁵⁾																																																																																																																																																																																																																												
Input Voltage for RL/UD	High ¹⁾	VIH ¹⁾	0.7VDD ²⁾	- ³⁾	VDD ⁴⁾	Volt ⁵⁾																																																																																																																																																																																																																												
	Low ¹⁾	VIL ¹⁾	0 ²⁾	- ³⁾	0.2VDD ²⁾	Volt ⁵⁾																																																																																																																																																																																																																												
	12		LED input current and power <table border="1"> <tr> <td>I_{LED}¹⁾</td> <td>Input Current¹⁾</td> <td>-²⁾</td> <td>0.12³⁾</td> <td>0.14³⁾</td> <td>A⁴⁾</td> </tr> <tr> <td>P_{LED}¹⁾</td> <td>Power Consumption¹⁾</td> <td>-²⁾</td> <td>1.44³⁾</td> <td>1.68³⁾</td> <td>W⁴⁾</td> </tr> </table>	I _{LED} ¹⁾	Input Current ¹⁾	- ²⁾	0.12 ³⁾	0.14 ³⁾	A ⁴⁾	P _{LED} ¹⁾	Power Consumption ¹⁾	- ²⁾	1.44 ³⁾	1.68 ³⁾	W ⁴⁾																																																																																																																																																																																																																			
I _{LED} ¹⁾	Input Current ¹⁾	- ²⁾	0.12 ³⁾	0.14 ³⁾	A ⁴⁾																																																																																																																																																																																																																													
P _{LED} ¹⁾	Power Consumption ¹⁾	- ²⁾	1.44 ³⁾	1.68 ³⁾	W ⁴⁾																																																																																																																																																																																																																													
		LED power 0.13W	LED power 1.28W																																																																																																																																																																																																																															
2.0 2014/3/20	6	2.2 Optical Characteristics Color/Chromaticity	2.2 Optical Characteristics Color/Chromaticity: Add RGBxy data																																																																																																																																																																																																																															
	12	5.1.2 Signal Electrical Characteristics Input Voltage for RL/UD	5.1.2 Signal Electrical Characteristics Input Voltage for RL/UD: Max 0.2 VDD																																																																																																																																																																																																																															
2.1 2015/1/20	11																																																																																																																																																																																																																																	
	16		Modify signal name																																																																																																																																																																																																																															
2.2 2021/6/4	12	<p>Note 1: Ta means ambient temperature of TFT-LCD module.</p> <p>Note 2: If G057QTN01.0 module is driven at high ambient temperature & humidity condition. The operating life will be reduced.</p> <p>Note 3: Operating life means brightness goes down to 50% initial brightness. Min. operating life time is estimated data.</p>	<p>Note 1: PWM dimming function can be operated by PWM signal. PWM duty cycle can adjust white Luminance. (PWM High: ON and PWM Low: OFF)</p> <p>Note 2: PWM signal g00_000 be floating and pull-down to ground when waiting.</p> <p>Note 3: V_{LED on/off} must be turned on later than V_{LED} and PWM Signal.</p> <p>Note 4: V_{LED on/off} must be turned off early than V_{LED} and PWM Signal.</p> <p>Note 5: If G057QTN01.0 module is driven by high current or at high ambient temperature & humidity condition. The operating life will be reduced.</p> <p>Note 6: Operating life means brightness goes down to 50% initial brightness. Minimum operating life time is estimated data.</p>																																																																																																																																																																																																																															
2.3 2021/6/11	10	4.1 Absolute Ratings of TFT LCD Module <table border="1"> <thead> <tr> <th>Item</th> <th>Symbol</th> <th>Min</th> <th>Max</th> <th>Unit</th> <th>Remark</th> </tr> </thead> <tbody> <tr> <td>Logic/LCD Drive Voltage</td> <td>VDD</td> <td>-0.3</td> <td>+5</td> <td>Volt</td> <td>Ta= 25°C</td> </tr> <tr> <td>LCD Input Signal Voltage</td> <td>VIN</td> <td>-0.3</td> <td>+5</td> <td>Volt</td> <td>Ta= 25°C</td> </tr> <tr> <td>LED BLU Drive Voltage</td> <td>V_{LED}</td> <td>24</td> <td>28.8</td> <td>Volt</td> <td>Ta= 25°C</td> </tr> <tr> <td>LED Dimming Input Voltage</td> <td>V_{PWM}</td> <td>0</td> <td>8</td> <td>Volt</td> <td>Ta= 25°C</td> </tr> <tr> <td>LED On/Off Input Voltage</td> <td>V_{LED on/off}</td> <td>0</td> <td>20</td> <td>Volt</td> <td>Ta= 25°C</td> </tr> </tbody> </table>	Item	Symbol	Min	Max	Unit	Remark	Logic/LCD Drive Voltage	VDD	-0.3	+5	Volt	Ta= 25°C	LCD Input Signal Voltage	VIN	-0.3	+5	Volt	Ta= 25°C	LED BLU Drive Voltage	V _{LED}	24	28.8	Volt	Ta= 25°C	LED Dimming Input Voltage	V _{PWM}	0	8	Volt	Ta= 25°C	LED On/Off Input Voltage	V _{LED on/off}	0	20	Volt	Ta= 25°C	4.1 Absolute Ratings of TFT LCD Module <table border="1"> <thead> <tr> <th>Item</th> <th>Symbol</th> <th>Min</th> <th>Max</th> <th>Unit</th> <th>Remark</th> </tr> </thead> <tbody> <tr> <td>Logic/LCD Drive Voltage</td> <td>VDD</td> <td>-0.3</td> <td>+5</td> <td>Volt</td> <td>Ta= 25°C</td> </tr> <tr> <td>LCD Input Signal Voltage</td> <td>VIN</td> <td>-0.3</td> <td>+5</td> <td>Volt</td> <td>Ta= 25°C</td> </tr> <tr> <td>LED Input Voltage</td> <td>V_{LED}</td> <td>24</td> <td>28.8</td> <td>Volt</td> <td>Ta= 25°C</td> </tr> <tr> <td>LED Dimming Voltage</td> <td>V_{PWM}</td> <td>0</td> <td>8</td> <td>Volt</td> <td>Ta= 25°C</td> </tr> <tr> <td>LED Enable Voltage</td> <td>V_{ENABLE}</td> <td>0</td> <td>20</td> <td>Volt</td> <td>Ta= 25°C</td> </tr> </tbody> </table>	Item	Symbol	Min	Max	Unit	Remark	Logic/LCD Drive Voltage	VDD	-0.3	+5	Volt	Ta= 25°C	LCD Input Signal Voltage	VIN	-0.3	+5	Volt	Ta= 25°C	LED Input Voltage	V _{LED}	24	28.8	Volt	Ta= 25°C	LED Dimming Voltage	V _{PWM}	0	8	Volt	Ta= 25°C	LED Enable Voltage	V _{ENABLE}	0	20	Volt	Ta= 25°C																																																																																																																																																							
Item	Symbol	Min	Max	Unit	Remark																																																																																																																																																																																																																													
Logic/LCD Drive Voltage	VDD	-0.3	+5	Volt	Ta= 25°C																																																																																																																																																																																																																													
LCD Input Signal Voltage	VIN	-0.3	+5	Volt	Ta= 25°C																																																																																																																																																																																																																													
LED BLU Drive Voltage	V _{LED}	24	28.8	Volt	Ta= 25°C																																																																																																																																																																																																																													
LED Dimming Input Voltage	V _{PWM}	0	8	Volt	Ta= 25°C																																																																																																																																																																																																																													
LED On/Off Input Voltage	V _{LED on/off}	0	20	Volt	Ta= 25°C																																																																																																																																																																																																																													
Item	Symbol	Min	Max	Unit	Remark																																																																																																																																																																																																																													
Logic/LCD Drive Voltage	VDD	-0.3	+5	Volt	Ta= 25°C																																																																																																																																																																																																																													
LCD Input Signal Voltage	VIN	-0.3	+5	Volt	Ta= 25°C																																																																																																																																																																																																																													
LED Input Voltage	V _{LED}	24	28.8	Volt	Ta= 25°C																																																																																																																																																																																																																													
LED Dimming Voltage	V _{PWM}	0	8	Volt	Ta= 25°C																																																																																																																																																																																																																													
LED Enable Voltage	V _{ENABLE}	0	20	Volt	Ta= 25°C																																																																																																																																																																																																																													
	12	5.2.1 Parameter guideline for LED Following characteristics are measured under stable condition using a LED driving board at 25°C (Room Temperature). <table border="1"> <thead> <tr> <th>Symbol</th> <th>Parameter</th> <th>Min</th> <th>Typ</th> <th>Max</th> <th>Units</th> <th>Remark</th> </tr> </thead> <tbody> <tr> <td>V_{LED}</td> <td>Input Voltage</td> <td>9</td> <td>12</td> <td>20</td> <td>Volt</td> <td></td> </tr> <tr> <td>I_{LED}</td> <td>Input Current</td> <td>-</td> <td>0.12</td> <td>0.14</td> <td>A</td> <td>V_{LED}=12V, D_{PWM}=100%</td> </tr> <tr> <td>P_{LED}</td> <td>Power Consumption</td> <td>-</td> <td>1.44</td> <td>1.68</td> <td>W</td> <td>V_{LED}=12V, D_{PWM}=100%</td> </tr> <tr> <td>I_{rush,LED}</td> <td>Inrush Current</td> <td>-</td> <td>-</td> <td>1.5</td> <td>A</td> <td>V_{LED}=12V, D_{PWM}=100%</td> </tr> <tr> <td>V_{PWM DIM}</td> <td>Dimming control Voltage High</td> <td>2.0</td> <td>3.3</td> <td>5</td> <td>Volt</td> <td rowspan="2">Note 1, 2</td> </tr> <tr> <td></td> <td>Dimming control Voltage Low</td> <td>-</td> <td>-</td> <td>0.15</td> <td>Volt</td> </tr> <tr> <td>F_{PWM}</td> <td>Dimming Frequency</td> <td>200</td> <td>-</td> <td>30K</td> <td>Hz</td> <td rowspan="2">Note 1, 2</td> </tr> <tr> <td>D_{PWM}</td> <td>Dimming duty cycle</td> <td>1</td> <td>-</td> <td>100</td> <td>%</td> </tr> <tr> <td>V_{LED on/off}</td> <td>On Control Voltage</td> <td>2</td> <td>3.3</td> <td>5</td> <td>Volt</td> <td rowspan="2">Note 3, 4</td> </tr> <tr> <td></td> <td>Off Control Voltage</td> <td>-</td> <td>-</td> <td>0.8</td> <td>Volt</td> </tr> <tr> <td>I_f</td> <td>LED Forward Current</td> <td>-</td> <td>50</td> <td>50</td> <td>mA</td> <td>Ta = 25°C</td> </tr> <tr> <td rowspan="2">V_f</td> <td rowspan="2">LED Forward Voltage</td> <td></td> <td></td> <td></td> <td>Volt</td> <td>IF = 50mA, Ta = -30°C</td> </tr> <tr> <td></td> <td>24</td> <td>25.6</td> <td>28.8</td> <td>Volt</td> <td>IF = 50mA, Ta = 25°C</td> </tr> <tr> <td></td> <td></td> <td></td> <td></td> <td></td> <td>Volt</td> <td>IF = 50mA, Ta = 85°C</td> </tr> <tr> <td>P_{LED}</td> <td>LED Power</td> <td>-</td> <td>1.28</td> <td>-</td> <td>Watt</td> <td></td> </tr> <tr> <td></td> <td>Operating Life</td> <td>50000</td> <td>-</td> <td>-</td> <td>Hrs</td> <td>Note 5, 6</td> </tr> </tbody> </table>	Symbol	Parameter	Min	Typ	Max	Units	Remark	V _{LED}	Input Voltage	9	12	20	Volt		I _{LED}	Input Current	-	0.12	0.14	A	V _{LED} =12V, D _{PWM} =100%	P _{LED}	Power Consumption	-	1.44	1.68	W	V _{LED} =12V, D _{PWM} =100%	I _{rush,LED}	Inrush Current	-	-	1.5	A	V _{LED} =12V, D _{PWM} =100%	V _{PWM DIM}	Dimming control Voltage High	2.0	3.3	5	Volt	Note 1, 2		Dimming control Voltage Low	-	-	0.15	Volt	F _{PWM}	Dimming Frequency	200	-	30K	Hz	Note 1, 2	D _{PWM}	Dimming duty cycle	1	-	100	%	V _{LED on/off}	On Control Voltage	2	3.3	5	Volt	Note 3, 4		Off Control Voltage	-	-	0.8	Volt	I _f	LED Forward Current	-	50	50	mA	Ta = 25°C	V _f	LED Forward Voltage				Volt	IF = 50mA, Ta = -30°C		24	25.6	28.8	Volt	IF = 50mA, Ta = 25°C						Volt	IF = 50mA, Ta = 85°C	P _{LED}	LED Power	-	1.28	-	Watt			Operating Life	50000	-	-	Hrs	Note 5, 6	5.2.1 Parameter guideline for LED Following characteristics are measured under stable condition using a LED driving board at 25°C (Room Temperature). <table border="1"> <thead> <tr> <th>Symbol</th> <th>Parameter</th> <th>Min</th> <th>Typ</th> <th>Max</th> <th>Units</th> <th>Remark</th> </tr> </thead> <tbody> <tr> <td>V_{LED}</td> <td>Input Voltage</td> <td>9</td> <td>12</td> <td>20</td> <td>Volt</td> <td></td> </tr> <tr> <td>I_{LED}</td> <td>Input Current</td> <td>-</td> <td>0.12</td> <td>0.14</td> <td>A</td> <td>V_{LED}=12V, D_{PWM}=100%</td> </tr> <tr> <td>P_{LED}</td> <td>Power Consumption</td> <td>-</td> <td>1.44</td> <td>1.68</td> <td>W</td> <td>V_{LED}=12V, D_{PWM}=100%</td> </tr> <tr> <td>I_{rush,LED}</td> <td>Inrush Current</td> <td>-</td> <td>-</td> <td>1.5</td> <td>A</td> <td>V_{LED}=12V, D_{PWM}=100%</td> </tr> <tr> <td rowspan="2">V_{PWM}</td> <td rowspan="2">Dimming control Voltage High</td> <td></td> <td>2.0</td> <td>3.3</td> <td>5</td> <td>Volt</td> <td rowspan="2">Note 1, 2</td> </tr> <tr> <td></td> <td>-</td> <td>-</td> <td>0.15</td> <td>Volt</td> </tr> <tr> <td rowspan="2">F_{PWM}</td> <td rowspan="2">Dimming Frequency</td> <td></td> <td>200</td> <td>-</td> <td>30K</td> <td>Hz</td> <td rowspan="2">Note 1, 2</td> </tr> <tr> <td></td> <td>1</td> <td>-</td> <td>100</td> <td>%</td> </tr> <tr> <td rowspan="2">V_{ENABLE}</td> <td rowspan="2">On Control Voltage</td> <td></td> <td>2</td> <td>3.3</td> <td>5</td> <td>Volt</td> <td rowspan="2">Note 3, 4</td> </tr> <tr> <td></td> <td>-</td> <td>-</td> <td>0.8</td> <td>Volt</td> </tr> <tr> <td rowspan="2">I_f</td> <td rowspan="2">LED Forward Current</td> <td></td> <td></td> <td>50</td> <td>mA</td> <td>Ta = 25°C</td> </tr> <tr> <td></td> <td>24</td> <td>25.6</td> <td>28.8</td> <td>Volt</td> <td>IF = 50mA, Ta = -30°C</td> </tr> <tr> <td></td> <td></td> <td></td> <td></td> <td></td> <td>Volt</td> <td>IF = 50mA, Ta = 85°C</td> </tr> <tr> <td>P_{LED}</td> <td>LED Power</td> <td>-</td> <td>1.28</td> <td>-</td> <td>Watt</td> <td></td> </tr> <tr> <td></td> <td>Operating Life</td> <td>50000</td> <td>-</td> <td>-</td> <td>Hrs</td> <td>Note 5, 6</td> </tr> </tbody> </table>	Symbol	Parameter	Min	Typ	Max	Units	Remark	V _{LED}	Input Voltage	9	12	20	Volt		I _{LED}	Input Current	-	0.12	0.14	A	V _{LED} =12V, D _{PWM} =100%	P _{LED}	Power Consumption	-	1.44	1.68	W	V _{LED} =12V, D _{PWM} =100%	I _{rush,LED}	Inrush Current	-	-	1.5	A	V _{LED} =12V, D _{PWM} =100%	V _{PWM}	Dimming control Voltage High		2.0	3.3	5	Volt	Note 1, 2		-	-	0.15	Volt	F _{PWM}	Dimming Frequency		200	-	30K	Hz	Note 1, 2		1	-	100	%	V _{ENABLE}	On Control Voltage		2	3.3	5	Volt	Note 3, 4		-	-	0.8	Volt	I _f	LED Forward Current			50	mA	Ta = 25°C		24	25.6	28.8	Volt	IF = 50mA, Ta = -30°C						Volt	IF = 50mA, Ta = 85°C	P _{LED}	LED Power	-	1.28	-	Watt			Operating Life	50000	-	-	Hrs	Note 5, 6
Symbol	Parameter	Min	Typ	Max	Units	Remark																																																																																																																																																																																																																												
V _{LED}	Input Voltage	9	12	20	Volt																																																																																																																																																																																																																													
I _{LED}	Input Current	-	0.12	0.14	A	V _{LED} =12V, D _{PWM} =100%																																																																																																																																																																																																																												
P _{LED}	Power Consumption	-	1.44	1.68	W	V _{LED} =12V, D _{PWM} =100%																																																																																																																																																																																																																												
I _{rush,LED}	Inrush Current	-	-	1.5	A	V _{LED} =12V, D _{PWM} =100%																																																																																																																																																																																																																												
V _{PWM DIM}	Dimming control Voltage High	2.0	3.3	5	Volt	Note 1, 2																																																																																																																																																																																																																												
	Dimming control Voltage Low	-	-	0.15	Volt																																																																																																																																																																																																																													
F _{PWM}	Dimming Frequency	200	-	30K	Hz	Note 1, 2																																																																																																																																																																																																																												
D _{PWM}	Dimming duty cycle	1	-	100	%																																																																																																																																																																																																																													
V _{LED on/off}	On Control Voltage	2	3.3	5	Volt	Note 3, 4																																																																																																																																																																																																																												
	Off Control Voltage	-	-	0.8	Volt																																																																																																																																																																																																																													
I _f	LED Forward Current	-	50	50	mA	Ta = 25°C																																																																																																																																																																																																																												
V _f	LED Forward Voltage				Volt	IF = 50mA, Ta = -30°C																																																																																																																																																																																																																												
			24	25.6	28.8	Volt	IF = 50mA, Ta = 25°C																																																																																																																																																																																																																											
					Volt	IF = 50mA, Ta = 85°C																																																																																																																																																																																																																												
P _{LED}	LED Power	-	1.28	-	Watt																																																																																																																																																																																																																													
	Operating Life	50000	-	-	Hrs	Note 5, 6																																																																																																																																																																																																																												
Symbol	Parameter	Min	Typ	Max	Units	Remark																																																																																																																																																																																																																												
V _{LED}	Input Voltage	9	12	20	Volt																																																																																																																																																																																																																													
I _{LED}	Input Current	-	0.12	0.14	A	V _{LED} =12V, D _{PWM} =100%																																																																																																																																																																																																																												
P _{LED}	Power Consumption	-	1.44	1.68	W	V _{LED} =12V, D _{PWM} =100%																																																																																																																																																																																																																												
I _{rush,LED}	Inrush Current	-	-	1.5	A	V _{LED} =12V, D _{PWM} =100%																																																																																																																																																																																																																												
V _{PWM}	Dimming control Voltage High		2.0	3.3	5	Volt	Note 1, 2																																																																																																																																																																																																																											
			-	-	0.15	Volt																																																																																																																																																																																																																												
F _{PWM}	Dimming Frequency		200	-	30K	Hz	Note 1, 2																																																																																																																																																																																																																											
			1	-	100	%																																																																																																																																																																																																																												
V _{ENABLE}	On Control Voltage		2	3.3	5	Volt	Note 3, 4																																																																																																																																																																																																																											
			-	-	0.8	Volt																																																																																																																																																																																																																												
I _f	LED Forward Current			50	mA	Ta = 25°C																																																																																																																																																																																																																												
			24	25.6	28.8	Volt	IF = 50mA, Ta = -30°C																																																																																																																																																																																																																											
					Volt	IF = 50mA, Ta = 85°C																																																																																																																																																																																																																												
P _{LED}	LED Power	-	1.28	-	Watt																																																																																																																																																																																																																													
	Operating Life	50000	-	-	Hrs	Note 5, 6																																																																																																																																																																																																																												

	<p>Note 1: PWM dimming function can be operated by PWM signal. PWM duty cycle can adjust white Luminance. (PWM High: ON and PWM Low: OFF)</p> <p>Note 2: PWM signal <code>cap_ncl</code> be floating and pull-down to ground when waiting.</p> <p>Note 3: <code>VLED On/Off</code> must be turned on late than <code>VLED</code> and PWM Signal.</p> <p>Note 4: <code>VLED On/Off</code> must be turned off early than <code>VLED</code> and PWM Signal.</p> <p>Note 5: If G057QTN01.0 module is driven by high current or at high ambient temperature & humidity condition. The operating life will be reduced.</p> <p>Note 6: Operating life means brightness goes down to 50% initial brightness. Minimum operating life time is estimated data.</p>	<p>Note 1: PWM dimming function can be operated by PWM signal. PWM duty cycle can adjust white Luminance. (PWM High: ON and PWM Low: OFF)</p> <p>Note 2: PWM signal <code>cap_ncl</code> be floating and pull-down to ground when waiting.</p> <p>Note 3: <code>VENABLE</code> must be turned on late than <code>VLED</code> and PWM Signal.</p> <p>Note 4: <code>VENABLE</code> must be turned off early than <code>VLED</code> and PWM Signal.</p> <p>Note 5: If G057QTN01.0 module is driven by high current or at high ambient temperature & humidity condition. The operating life will be reduced.</p> <p>Note 6: Operating life means brightness goes down to 50% initial brightness. Minimum operating life time is estimated data.</p>																																																																																																																																
<p>19</p>	<p>6.6 LED Backlight Unit Interface Signal Description</p> <table border="1"> <thead> <tr> <th>Pin #</th> <th>Symbol</th> <th>Pin Description</th> </tr> </thead> <tbody> <tr> <td>1</td> <td>VLED</td> <td>12V input</td> </tr> <tr> <td>2</td> <td>VLED</td> <td>12V input</td> </tr> <tr> <td>3</td> <td>GND</td> <td>Ground</td> </tr> <tr> <td>4</td> <td>GND</td> <td>Ground</td> </tr> <tr> <td>5</td> <td>PWM DIM</td> <td>1~100% PWM dimming</td> </tr> <tr> <td>6</td> <td>LED On/Off</td> <td>0V-Off, 2~5V/NC-On</td> </tr> </tbody> </table> <p>Note 1: "NC" stands for "No Connection"</p> <p>6.7 Power ON/OFF Sequence</p> <p>VDD power and LED on/off sequence is as below. Interface signals are also shown in the chart. Signals from any system shall be Hi-Z state or low level when VDD is off.</p>	Pin #	Symbol	Pin Description	1	VLED	12V input	2	VLED	12V input	3	GND	Ground	4	GND	Ground	5	PWM DIM	1~100% PWM dimming	6	LED On/Off	0V-Off, 2~5V/NC-On	<p>6.6 LED Backlight Unit Interface Signal Description</p> <table border="1"> <thead> <tr> <th>Pin #</th> <th>Symbol</th> <th>Pin Description</th> </tr> </thead> <tbody> <tr> <td>1</td> <td>VLED</td> <td>12V input</td> </tr> <tr> <td>2</td> <td>VLED</td> <td>12V input</td> </tr> <tr> <td>3</td> <td>GND</td> <td>Ground</td> </tr> <tr> <td>4</td> <td>GND</td> <td>Ground</td> </tr> <tr> <td>5</td> <td>VPWM</td> <td>1~100% PWM dimming</td> </tr> <tr> <td>6</td> <td>VENABLE</td> <td>0V-Off, 2~5V/NC-On</td> </tr> </tbody> </table> <p>Note 1: "NC" stands for "No Connection"</p> <p>6.7 Power ON/OFF Sequence</p> <p>VDD power and LED on/off sequence is as below. Interface signals are also shown in the chart. Signals from any system shall be Hi-Z state or low level when VDD is off.</p>	Pin #	Symbol	Pin Description	1	VLED	12V input	2	VLED	12V input	3	GND	Ground	4	GND	Ground	5	VPWM	1~100% PWM dimming	6	VENABLE	0V-Off, 2~5V/NC-On																																																																																						
Pin #	Symbol	Pin Description																																																																																																																																
1	VLED	12V input																																																																																																																																
2	VLED	12V input																																																																																																																																
3	GND	Ground																																																																																																																																
4	GND	Ground																																																																																																																																
5	PWM DIM	1~100% PWM dimming																																																																																																																																
6	LED On/Off	0V-Off, 2~5V/NC-On																																																																																																																																
Pin #	Symbol	Pin Description																																																																																																																																
1	VLED	12V input																																																																																																																																
2	VLED	12V input																																																																																																																																
3	GND	Ground																																																																																																																																
4	GND	Ground																																																																																																																																
5	VPWM	1~100% PWM dimming																																																																																																																																
6	VENABLE	0V-Off, 2~5V/NC-On																																																																																																																																
<p>21</p>	<p>7.1 TFT- LCD Signal (CN1): LCD Connector</p> <table border="1"> <thead> <tr> <th colspan="2">Manufacturer</th> <th colspan="2">Starconn</th> </tr> <tr> <th colspan="2">Connector Model Number</th> <th colspan="2">089H33-000100-G2-R, compatible with MS2406P33M</th> </tr> </thead> <tbody> <tr> <td>Pin#</td> <td>Symbol</td> <td>Pin#</td> <td>Symbol</td> <td>Pin#</td> <td>Symbol</td> </tr> <tr> <td>1</td> <td>GND</td> <td>12</td> <td>GND</td> <td>23</td> <td>B3</td> </tr> <tr> <td>2</td> <td>DOTCLK</td> <td>13</td> <td>G0</td> <td>24</td> <td>B4</td> </tr> <tr> <td>3</td> <td>NC</td> <td>14</td> <td>G1</td> <td>25</td> <td>B5</td> </tr> <tr> <td>4</td> <td>NC</td> <td>15</td> <td>G2</td> <td>26</td> <td>GND</td> </tr> <tr> <td>5</td> <td>GND</td> <td>16</td> <td>G3</td> <td>27</td> <td>DE</td> </tr> <tr> <td>6</td> <td>R0</td> <td>17</td> <td>G4</td> <td>28</td> <td>VDD</td> </tr> <tr> <td>7</td> <td>R1</td> <td>18</td> <td>G5</td> <td>29</td> <td>VDD</td> </tr> <tr> <td>8</td> <td>R2</td> <td>19</td> <td>GND</td> <td>30</td> <td>R/L</td> </tr> <tr> <td>9</td> <td>R3</td> <td>20</td> <td>B0</td> <td>31</td> <td>U/D</td> </tr> <tr> <td>10</td> <td>R4</td> <td>21</td> <td>B1</td> <td>32</td> <td>NC</td> </tr> <tr> <td>11</td> <td>R5</td> <td>22</td> <td>B2</td> <td>33</td> <td>GND</td> </tr> </tbody> </table> <p>7.2 LED Backlight Unit (CN2): Backlight Connector</p> <table border="1"> <thead> <tr> <th colspan="2">Manufacturer</th> <th colspan="2">JST</th> </tr> <tr> <th colspan="2">Connector Model Number</th> <th colspan="2">SM06B-SRKS-G-TB compatible with JST SM06B-SRSS-TB (LS) (SN)</th> </tr> <tr> <th colspan="2">Mating Connector Model Number</th> <th colspan="2">JST SHR-06V-BKHF-B or compatible</th> </tr> </thead> <tbody> <tr> <td>Pin #</td> <td>Symbol</td> <td>Pin #</td> <td>Symbol</td> </tr> <tr> <td>1</td> <td>VLED</td> <td>4</td> <td>GND</td> </tr> <tr> <td>2</td> <td>VLED</td> <td>5</td> <td>PWM DIM</td> </tr> <tr> <td>3</td> <td>GND</td> <td>6</td> <td>LED ON/OFF</td> </tr> </tbody> </table>	Manufacturer		Starconn		Connector Model Number		089H33-000100-G2-R, compatible with MS2406P33M		Pin#	Symbol	Pin#	Symbol	Pin#	Symbol	1	GND	12	GND	23	B3	2	DOTCLK	13	G0	24	B4	3	NC	14	G1	25	B5	4	NC	15	G2	26	GND	5	GND	16	G3	27	DE	6	R0	17	G4	28	VDD	7	R1	18	G5	29	VDD	8	R2	19	GND	30	R/L	9	R3	20	B0	31	U/D	10	R4	21	B1	32	NC	11	R5	22	B2	33	GND	Manufacturer		JST		Connector Model Number		SM06B-SRKS-G-TB compatible with JST SM06B-SRSS-TB (LS) (SN)		Mating Connector Model Number		JST SHR-06V-BKHF-B or compatible		Pin #	Symbol	Pin #	Symbol	1	VLED	4	GND	2	VLED	5	PWM DIM	3	GND	6	LED ON/OFF	<p>7.1 TFT- LCD Signal (CN1): LCD Connector</p> <table border="1"> <thead> <tr> <th colspan="2">Manufacturer</th> <th colspan="2">Starconn</th> </tr> <tr> <th colspan="2">Connector Model Number</th> <th colspan="2">089H33-000100-G2-R, compatible with MS2406P33M</th> </tr> </thead> </table> <p>7.2 LED Backlight Unit (CN2): Backlight Connector</p> <table border="1"> <thead> <tr> <th colspan="2">Manufacturer</th> <th colspan="2">JST</th> </tr> <tr> <th colspan="2">Connector Model Number</th> <th colspan="2">SM06B-SRKS-G-TB compatible with JST SM06B-SRSS-TB (LS) (SN)</th> </tr> <tr> <th colspan="2">Mating Connector Model Number</th> <th colspan="2">JST SHR-06V-BKHF-B or compatible</th> </tr> </thead> </table>	Manufacturer		Starconn		Connector Model Number		089H33-000100-G2-R, compatible with MS2406P33M		Manufacturer		JST		Connector Model Number		SM06B-SRKS-G-TB compatible with JST SM06B-SRSS-TB (LS) (SN)		Mating Connector Model Number		JST SHR-06V-BKHF-B or compatible	
Manufacturer		Starconn																																																																																																																																
Connector Model Number		089H33-000100-G2-R, compatible with MS2406P33M																																																																																																																																
Pin#	Symbol	Pin#	Symbol	Pin#	Symbol																																																																																																																													
1	GND	12	GND	23	B3																																																																																																																													
2	DOTCLK	13	G0	24	B4																																																																																																																													
3	NC	14	G1	25	B5																																																																																																																													
4	NC	15	G2	26	GND																																																																																																																													
5	GND	16	G3	27	DE																																																																																																																													
6	R0	17	G4	28	VDD																																																																																																																													
7	R1	18	G5	29	VDD																																																																																																																													
8	R2	19	GND	30	R/L																																																																																																																													
9	R3	20	B0	31	U/D																																																																																																																													
10	R4	21	B1	32	NC																																																																																																																													
11	R5	22	B2	33	GND																																																																																																																													
Manufacturer		JST																																																																																																																																
Connector Model Number		SM06B-SRKS-G-TB compatible with JST SM06B-SRSS-TB (LS) (SN)																																																																																																																																
Mating Connector Model Number		JST SHR-06V-BKHF-B or compatible																																																																																																																																
Pin #	Symbol	Pin #	Symbol																																																																																																																															
1	VLED	4	GND																																																																																																																															
2	VLED	5	PWM DIM																																																																																																																															
3	GND	6	LED ON/OFF																																																																																																																															
Manufacturer		Starconn																																																																																																																																
Connector Model Number		089H33-000100-G2-R, compatible with MS2406P33M																																																																																																																																
Manufacturer		JST																																																																																																																																
Connector Model Number		SM06B-SRKS-G-TB compatible with JST SM06B-SRSS-TB (LS) (SN)																																																																																																																																
Mating Connector Model Number		JST SHR-06V-BKHF-B or compatible																																																																																																																																
<p>2.4 2021/6/16</p>	<p>8</p>	<p>Note 8: Note 8: Definition of Gamma Value</p>	<p>Remove the Note 8</p>																																																																																																																															

1. Operating Precautions

- 1) Since front polarizer is easily damaged, please be cautious and not to scratch it.
- 2) Be sure to turn off power supply when inserting or disconnecting from input connector.
- 3) Wipe off water drop immediately. Long contact with water may cause discoloration or spots.
- 4) When the panel surface is soiled, wipe it with absorbent cotton or soft cloth.
- 5) Since the panel is made of glass, it may be broken or cracked if dropped or bumped on hard surface.
- 6) Since CMOS LSI is used in this module, take care of static electricity and insure human earth when handling.
- 7) Do not open nor modify the module assembly.
- 8) Do not press the reflector sheet at the back of the module to any direction.
- 9) In case if a module has to be put back into the packing container slot after it was taken out from the container, do not press the center of the LED Reflector edge. Instead, press at the far ends of the LED Reflector edge softly. Otherwise the TFT Module may be damaged.
- 10) At the insertion or removal of the Signal Interface Connector, be sure not to rotate nor tilt the Interface Connector of the TFT Module.
- 11) TFT-LCD Module is not allowed to be twisted & bent even force is added on module in a very short time. Please design your display product well to avoid external force applying to module by end-user directly.
- 12) Small amount of materials without flammability grade are used in the TFT-LCD module. The TFT-LCD module should be supplied by power complied with requirements of Limited Power Source (IEC60950-1 or UL60950-1), or be applied exemption.
- 13) Severe temperature condition may result in different luminance, response time.
- 14) Continuous operating TFT-LCD Module under high temperature environment may accelerate LED light bar exhaustion and reduce luminance dramatically.
- 15) The data on this specification sheet is applicable when TFT-LCD module is placed in landscape position.
- 16) Continuous displaying fixed pattern may induce image sticking. It's recommended to use screen saver or moving content periodically if fixed pattern is displayed on the screen.

2. General Description

G057QTN01.0 is a Color Active Matrix Liquid Crystal Display composed of a TFT-LCD display, a driver circuit, and a backlight system. The screen format is intended to support QVGA (320(H) x 240(V)) screen and 262K (RGB 6-bits). All input signals are CMOS interface compatible.

G057QTN01.0 is designed for industrial display applications.

2.1 Display Characteristics

The following items are characteristics summary on the table under 25 °C condition:

Items	Unit	Specifications
Screen Diagonal	[inch]	5.7
Active Area	[mm]	115.2(H) x 86.4(V)
Pixels H x V		320x3(RGB)x240
Pixel Pitch	[mm]	0.36 x 0.36
Pixel Arrangement		R.G.B. Vertical Stripe
Display Mode		TN, Normally White
Nominal Input Voltage VDD	[Volt]	3.3 typ.
Typical Power Consumption	[Watt]	1.9 W (LCD: 0.46 W/LED BLU: 1.44 W) @ All black pattern, Full Load and V _{LED} =12V
Weight	[Grams]	150g (typ.), 165g (max.)
Physical Size	[mm]	144.0(H)x 104.6(V) x 12.3(D) (typ.)
Electrical Interface		CMOS 6-bit Parallel RGB
Surface Treatment		Anti-Glare, Hardness 3H
Support Color		262K colors
Temperature Range Operating Storage (Non-Operating)	[°C] [°C]	-30 to +85 -30 to +85
RoHS Compliance		RoHS Compliance
Light Bar Unit		LED, Replaceable

2.2 Optical Characteristics

The optical characteristics are measured under stable conditions at 25°C (Room Temperature):

Item	Unit	Conditions	Min.	Typ.	Max.	Note
White Luminance	[cd/m ²]	V _{LED} =12V, D _{PWM} =100% (center point)	400	500	-	1
Uniformity		5 Points			1.3	1, 2, 3
Contrast Ratio			500	700	-	4
Cross talk	%		-	1.2	1.5	5
Response Time	[msec]	Rising	-	15	20	6
	[msec]	Falling	-	10	15	
	[msec]	Raising + Falling	-	25	35	
Viewing Angle	[degree]	Horizontal (Right) CR = 10 (Left)	70	80	-	7
	[degree]		70	80	-	
	[degree]	Vertical (Upper) CR = 10 (Lower)	60	70	-	
	[degree]		60	70	-	
Color / Chromaticity Coordinates (CIE 1931)		White x	0.263	0.313	0.363	
		White y	0.279	0.329	0.379	
		Red x	0.491	0.541	0.591	
		Red y	0.253	0.303	0.353	
		Green x	0.279	0.329	0.379	
		Green y	0.559	0.609	0.659	
		Blue x	0.111	0.161	0.211	
		Blue y	0.064	0.114	0.164	
Color Gamut	%			50		

Note 1: Measurement method

Equipment Pattern Generator, Power Supply, Digital Voltmeter, Luminance meter (SR_3 or equivalent)

Aperture 1° with 50cm viewing distance

Test Point Center

Environment < 1 lux

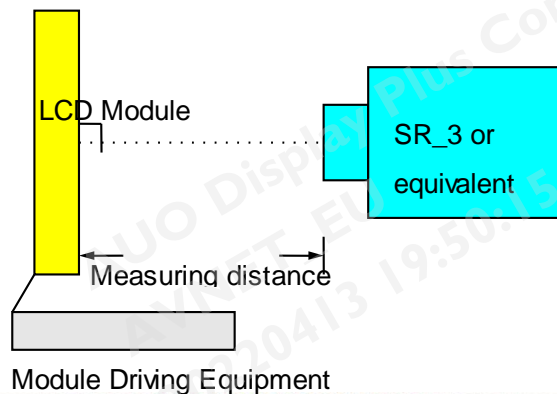

Note 2: Definition of 9 points position (Display active area: 115.2(H) x 86.4(V))

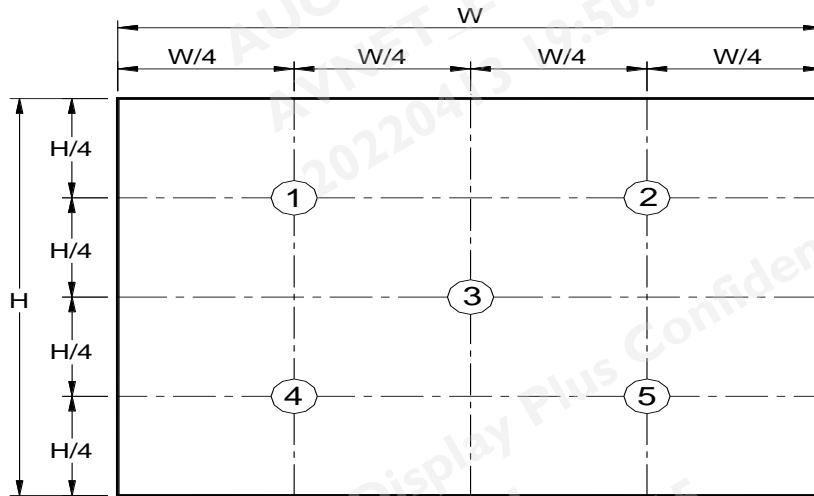

Note 3: The luminance uniformity of 9 points is defined by dividing the minimum luminance values by the maximum test point luminance

$$\delta_{w9} = \frac{\text{Minimum Brightness of nine points}}{\text{Maximum Brightness of nine points}}$$

Note 4 : Definition of contrast ratio (CR):

$$\text{Contrast ratio (CR)} = \frac{\text{Brightness on the "White" state}}{\text{Brightness on the "Black" state}}$$

Note 5 : Definition of cross talk (CT)

$$CT = |YB - YA| / YA \times 100 (\%)$$

Where

YA = Luminance of measured location without gray level 0 pattern (cd/m²)

YB = Luminance of measured location with gray level 0 pattern (cd/m²)

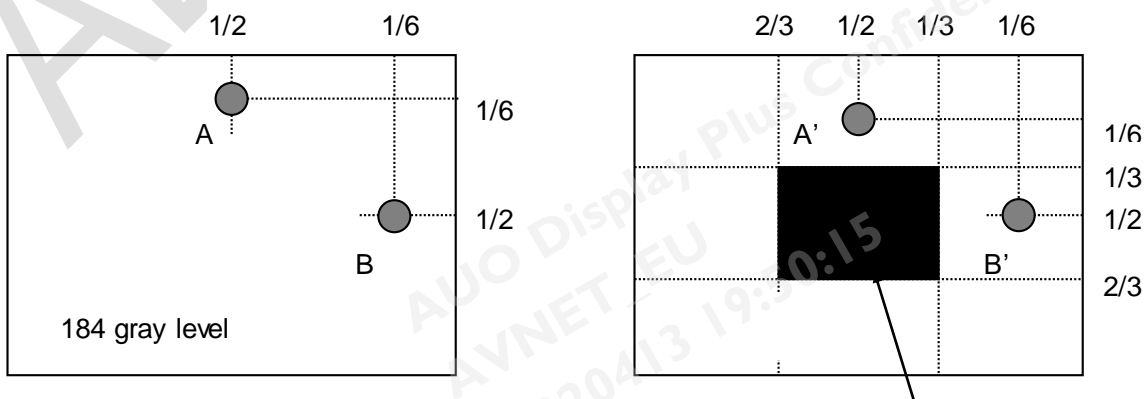



AUO Display Plus Confidential
AVNET_EU
20220413 19:50:15

AUO Display Plus Confidential
AVNET_EU
20220413 19:50:15

ADP Confidential

AUO Display Plus Confidential
AVNET_EU
20220413 19:50:15

AUO Display Plus Confidential
AVNET_EU
20220413 19:50:15

Note 6: Definition of response time:

The output signals of photo detector are measured when the input signals are changed from “White” to “Black” (falling time) and from “Black” to “White” (rising time), respectively. The response time interval is between 10% and 90% of amplitudes. Please refer to the figure as below.

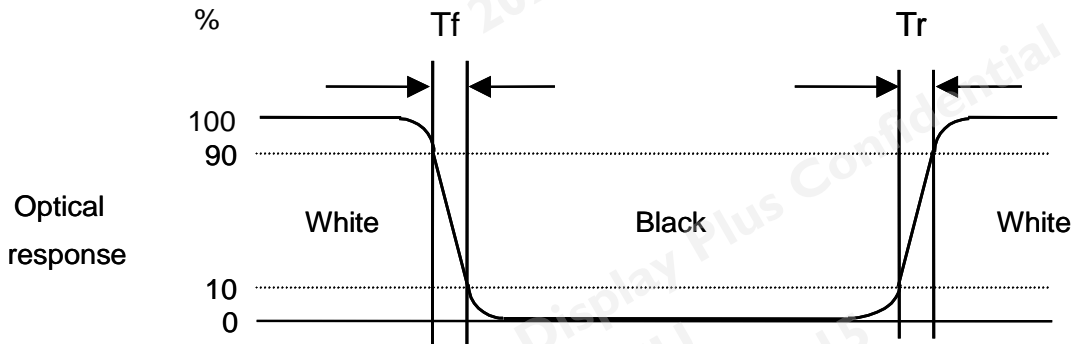

Note 7: Definition of viewing angle

Viewing angle is the measurement of contrast ratio ≥ 10 , at the screen center, over a 180° horizontal and 180° vertical range (off-normal viewing angles). The 180° viewing angle range is broken down as below: 90° (θ) horizontal left and right, and 90° (Φ) vertical high (up) and low (down). The measurement direction is typically perpendicular to the display surface with the screen rotated to its center to develop the desired measurement viewing angle.

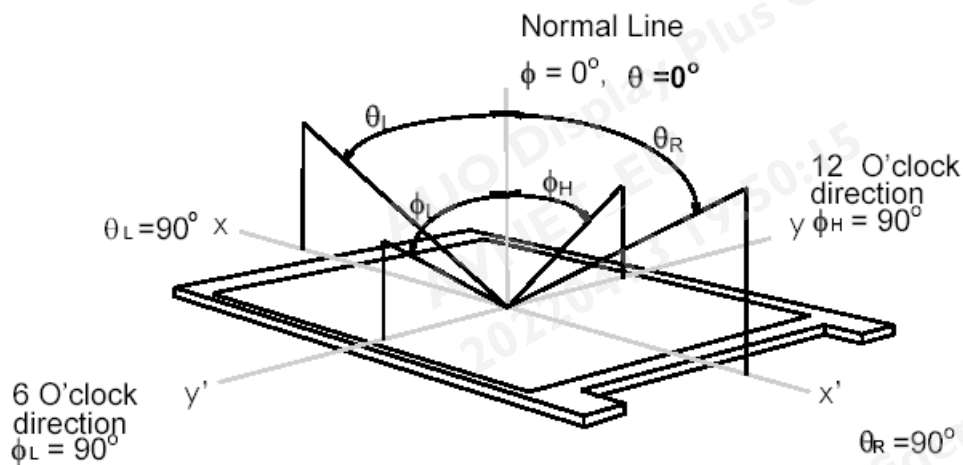

Generally, Gamma Value is defined as the slope of a Gray Level – Luminance curve in log-log space, that is

$$\gamma = d \log(\text{Luminance}) / d \log(\text{Gray Level})$$

The Gamma Value defined in this spec is Linear Regression ($\gamma_1, \gamma_2, \gamma_3 \dots, \gamma_{16}$). γ_1 to γ_{16} are the

section gamma of the following 17 sampling points, GL(0), GL(16), GL(32), GL(48), GL(64), GL(80), GL(96), GL(112), GL(128), GL(144), GL(160), GL(176), GL(192), GL(208), GL(224), GL(240) and GL(255), in 8 bits input.

ADP Confidential

AUO Display Plus Confidential
AVNET_EU
20220413 19:50:15

AUO Display Plus Confidential
AVNET_EU
20220413 19:50:15

AUO Display Plus Confidential
AVNET_EU
20220413 19:50:15

3. Functional Block Diagram

The following diagram shows the functional block of the 5.7 inch color TFT/LCD module:

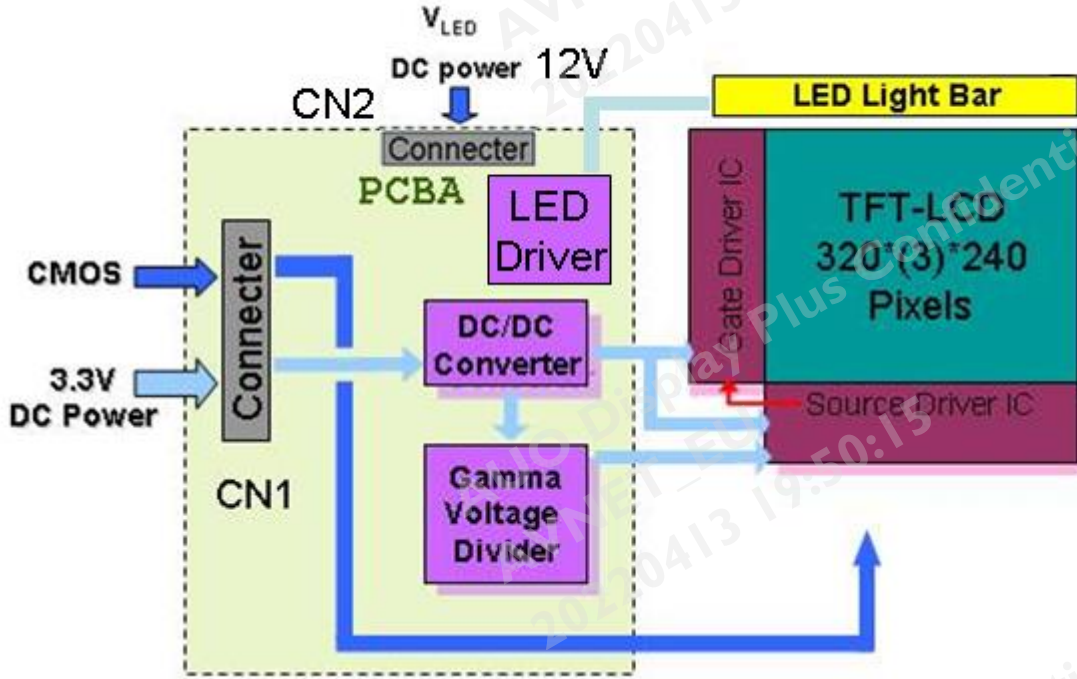

4. Absolute Maximum Ratings

4.1 Absolute Ratings of TFT LCD Module

Item	Symbol	Min	Max	Unit	Remark
Logic/LCD Drive Voltage	VDD	-0.3	+5	Volt	Ta= 25°C
LCD Input Signal Voltage	VIN	-0.3	+5	Volt	Ta= 25°C
LED Input Voltage	V _{LED}	24	28.8	Volt	Ta= 25°C
LED Dimming Voltage	V _{PWM}	0	8	Volt	Ta= 25°C
LED Enable Voltage	V _{Enable}	0	20	Volt	Ta= 25°C

4.2 Absolute Ratings of Environment

Item	Symbol	Min	Max	Unit	Remark
Operating Temperature	TOP	-30	+85	°C	Note 1, 2
Operation Humidity	HOP	5	90	%RH	Note 1, 2
Storage Temperature	TST	-30	+85	°C	Note 1
Storage Humidity	HST	5	90	%RH	Note 1

Note 1: Maximum Wet-Bulb should be 39°C and no condensation.

Note 2: Only operation is guaranteed. Optical performance should be evaluated at 25°C only.

5. Electrical Characteristics

5.1 TFT LCD Module

5.1.1 Power Specification

Symbol	Parameter	Min	Typ	Max	Units	Remark
VDD	Logic/LCD Drive Voltage	3.0	3.3	3.6	[Volt]	
IDD	VDD Current	-	115	130	[mA]	All Black Pattern (VDD=3.3V, at 60Hz)
Irush	LCD Inrush Current	-	-	1.5	[A]	Note 1
PDD	VDD Power		0.46	0.51	[Watt]	All Black Pattern (VDD=3.3V, at 60Hz)
VDDrp	Allowable Logic/LCD Drive Ripple Voltage	-	-	100	mVp-p	All Black Pattern (VDD=3.3V, at 60Hz)

Note 1: Measurement condition:

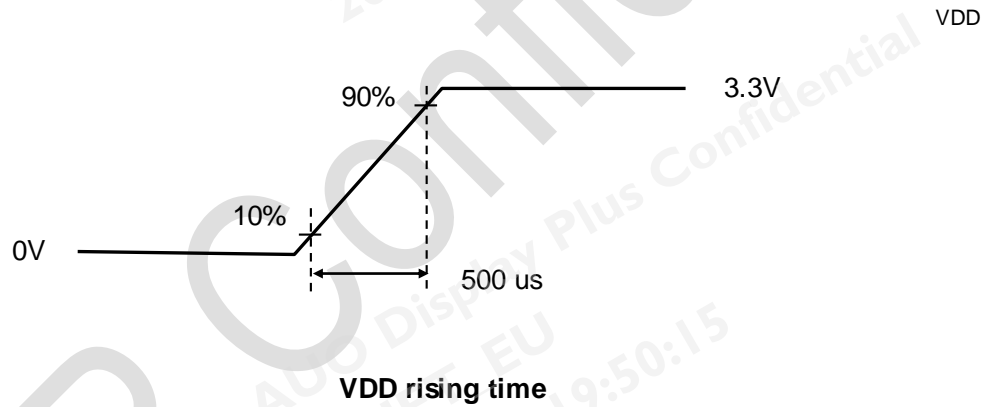

5.1.2 Signal Electrical Characteristics

Input signals shall be low or Hi-Z state when VDD is off.

Parameter		Symbol	Min.	Typ.	Max.	Unit	Remarks
Logic Input Voltage for Display Signals	High	V _{IH}	0.7VDD	-	VDD	Volt	
	Low	V _{IL}	0	-	0.3VDD	Volt	
Input Voltage for RL/UD	High	V _{IH}	0.7VDD	-	VDD	Volt	
	Low	V _{IL}	0	-	0.2VDD	Volt	

5.2 Backlight Unit

5.2.1 Parameter guideline for LED

Following characteristics are measured under stable condition using a LED driving board at 25°C (Room Temperature).

Symbol	Parameter	Min	Typ	Max	Units	Remark
V _{LED}	Input Voltage	9	12	20	Volt	
I _{LED}	Input Current	-	0.12	0.14	A	V _{LED} = 12V, D _{PWM} = 100%
P _{LED}	Power Consumption	-	1.44	1.68	W	V _{LED} = 12V, D _{PWM} = 100%
I _{rushLED}	Inrush Current	-		1.5	A	V _{LED} = 12V, D _{PWM} = 100%
V _{PWM}	Dimming control Voltage High	2.0	3.3	5	Volt	Note 1,2
	Dimming control Voltage Low	-	-	0.15	Volt	
F _{PWM}	Dimming Frequency	200		30K	Hz	
D _{PWM}	Dimming duty cycle	1		100	%	
V _{ENABLE}	On Control Voltage	2	3.3	5	Volt	Note 3, 4
	Off Control Voltage	-	-	0.8	Volt	
I _F	LED Forward Current		50		mA	T _a = 25oC
V _F	LED Forward Voltage				Volt	I _F = 50mA, T _a = -30oC
		24	25.6	28.8	Volt	I _F = 50mA, T _a = 25oC
					Volt	I _F = 50mA, T _a = 85oC
P _{LED}	LED Power		1.28		Watt	
Operating Life		50000	-	-	Hrs	Note 5, 6

Note 1: PWM dimming function can be operated by PWM signal. PWM duty cycle can adjust white Luminance.
(PWM High: ON and PWM Low: OFF)

Note 2: PWM signal can not be floating and pull-down to ground when waiting.

Note 3: V_{ENABLE} must be turned on late than V_{LED} and PWM Signal.

Note 4: V_{ENABLE} must be turned off early than V_{LED} and PWM Signal.

Note 5: If G057QTN01.0 module is driven by high current or at high ambient temperature & humidity condition.
The operating life will be reduced.

Note 6: Operating life means brightness goes down to 50% initial brightness. Minimum operating life time is estimated data.

6. Signal Characteristic

6.1 Pixel Format Image

Following figure shows the relationship between input signal and LCD pixel format.

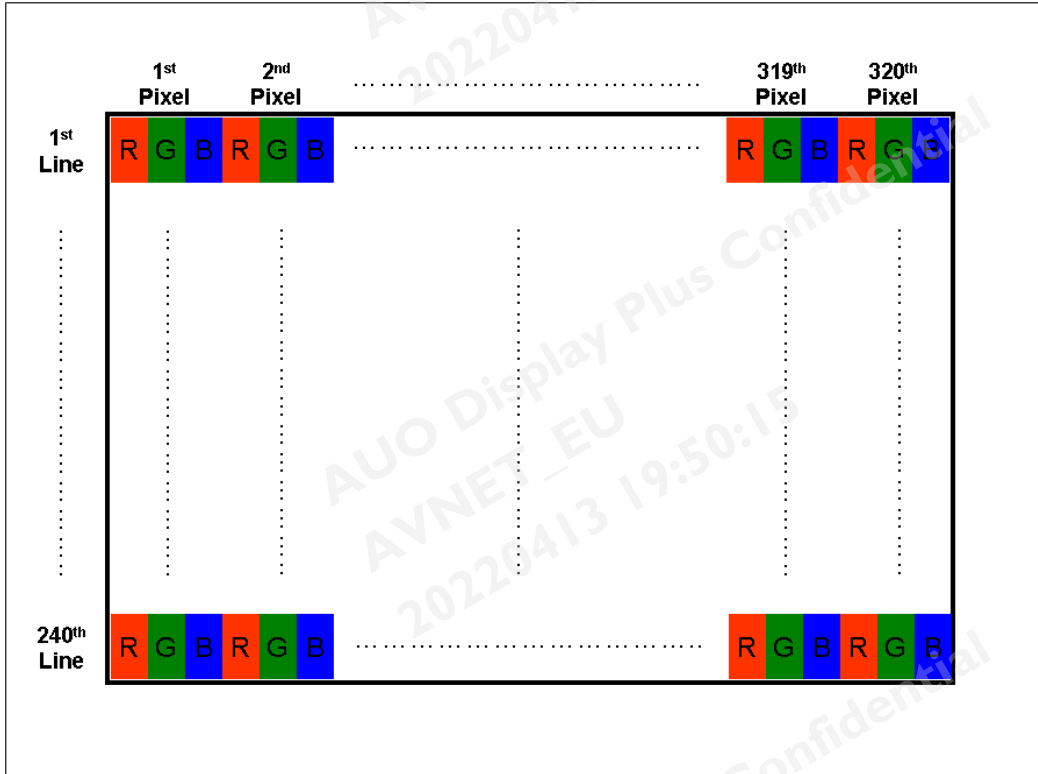

6.2 Scanning Direction

The following figures show the image seen from the front view. The arrow indicates the direction of scan.

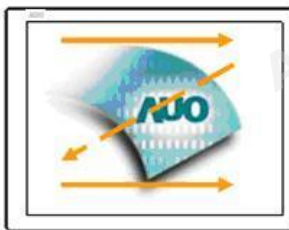

R/L=Low or NC; U/D=High or NC



R/L=High; U/D=High or NC

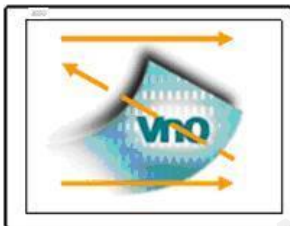

R/L=Low or NC; U/D=Low



R/L=High; U/D=Low



AUO Display Plus Confidential
AVNET_EU
20220413 19:50:15

AUO Display Plus Confidential
AVNET_EU
20220413 19:50:15

ADP Confidential

AUO Display Plus Confidential
AVNET_EU
20220413 19:50:15

AUO Display Plus Confidential
AVNET_EU
20220413 19:50:15

6.3 TFT- LCD Interface Signal Description

Pin#	Signal Name	Description
1	GND	Ground
2	DOTCLK	Dot clock
3	NC	NC
4	NC	NC
5	GND	Ground
6	R0	Red data(LSB)
7	R1	Red data
8	R2	Red data
9	R3	Red data
10	R4	Red data
11	R5	Red data(MSB)
12	GND	Ground
13	G0	Green data(LSB)
14	G1	Green data
15	G2	Green data
16	G3	Green data
17	G4	Green data
18	G5	Green data(MSB)
19	GND	Ground
20	B0	Blue data(LSB)
21	B1	Blue data
22	B2	Blue data
23	B3	Blue data
24	B4	Blue data
25	B5	Blue data(MSB)
26	GND	Ground
27	DE	Data enable signal
28	VDD	Power supply (3.3V Typ. Only)
29	VDD	Power supply (3.3V Typ. Only)
30	R/L	Horizontal reverse scan
31	U/D	Vertical reverse scan
32	NC	NC
33	GND	Ground

Note 1: "Low" stands for 0V. "High" stands for 3.3V. "NC" stands for "No Connection".

6.4 The Input Data Format

This product displays 262,144 colors in terms of the 64 grey levels on RGB respectively. The following table demonstrates the display of input data.

Display colors		Data signal (0 : Low level, 1: High level)																	
		R5	R4	R3	R2	R1	R0	G5	G4	G3	G2	G1	G0	B5	B4	B3	B2	B1	B0
Basic colors	Black	0	0	0	0	0	0	0	0	0	0	0	0	0	0	0	0	0	0
	Blue	0	0	0	0	0	0	0	0	0	0	0	0	1	1	1	1	1	1
	Red	1	1	1	1	1	1	0	0	0	0	0	0	0	0	0	0	0	0
	Magenta	1	1	1	1	1	1	0	0	0	0	0	0	1	1	1	1	1	1
	Green	0	0	0	0	0	0	1	1	1	1	1	1	0	0	0	0	0	0
	Cyan	0	0	0	0	0	0	1	1	1	1	1	1	1	1	1	1	1	1
	Yellow	1	1	1	1	1	1	1	1	1	1	1	1	0	0	0	0	0	0
	White	1	1	1	1	1	1	1	1	1	1	1	1	1	1	1	1	1	1
Red grayscale	Black	0	0	0	0	0	0	0	0	0	0	0	0	0	0	0	0	0	0
	Dark	0	0	0	0	0	1	0	0	0	0	0	0	0	0	0	0	0	0
	↑ ↓ bright																		
		1	1	1	1	0	1	0	0	0	0	0	0	0	0	0	0	0	0
	Red	1	1	1	1	1	0	0	0	0	0	0	0	0	0	0	0	0	0
Green grayscale	Black	0	0	0	0	0	0	0	0	0	0	0	0	0	0	0	0	0	0
	Dark	0	0	0	0	0	0	0	0	0	0	0	1	0	0	0	0	0	0
	↑ ↓ bright																		
		0	0	0	0	0	0	1	1	1	1	0	1	0	0	0	0	0	0
	Green	0	0	0	0	0	0	1	1	1	1	1	0	0	0	0	0	0	0
Blue grayscale	Black	0	0	0	0	0	0	0	0	0	0	0	0	0	0	0	0	0	0
	Dark	0	0	0	0	0	0	0	0	0	0	0	0	0	0	0	0	0	1
	↑ ↓ bright																		
		0	0	0	0	0	0	0	0	0	0	0	0	1	1	1	1	0	1
	Blue	0	0	0	0	0	0	0	0	0	0	0	0	1	1	1	1	1	0

6.5 Interface Timing

6.5.1 Timing Characteristics

Signal	Parameter	Symbol	Min.	Typ.	Max.	Unit	
Clock Timing	Clock frequency	$1/T_{\text{Clock}}$	6.2	6.4	12.1	MHz	
Data	Setup Time	T_{dsu}	8				
	Hold Time	T_{dhd}	8				
DE	Setup Time	T_{esu}	8				
Hsync Timing	Horizontal Section	Period	T_{H}	406	408	560	T_{Clock}
		Active	T_{HD}	320			
		Blanking	T_{HB}	86	88	240	
Vsync Timing	Vertical Section	Period	T_{V}	254	263	360	T_{Line}
		Active	T_{VD}	240			
		Blanking	T_{VB}	14	23	120	
Frame Rate		F	-	60	-	Hz	

Note: DE mode only.

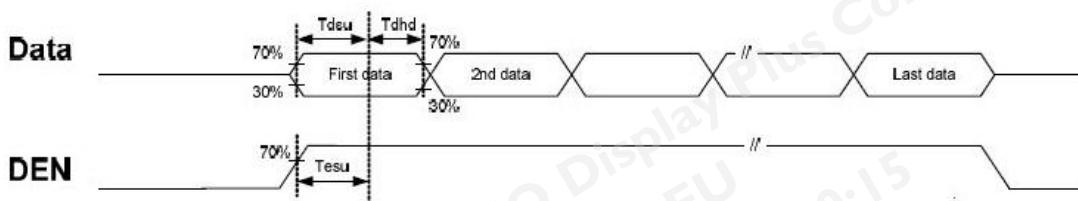

6.5.2 Input Timing Diagram

Input Timing Definition (DE Mode)

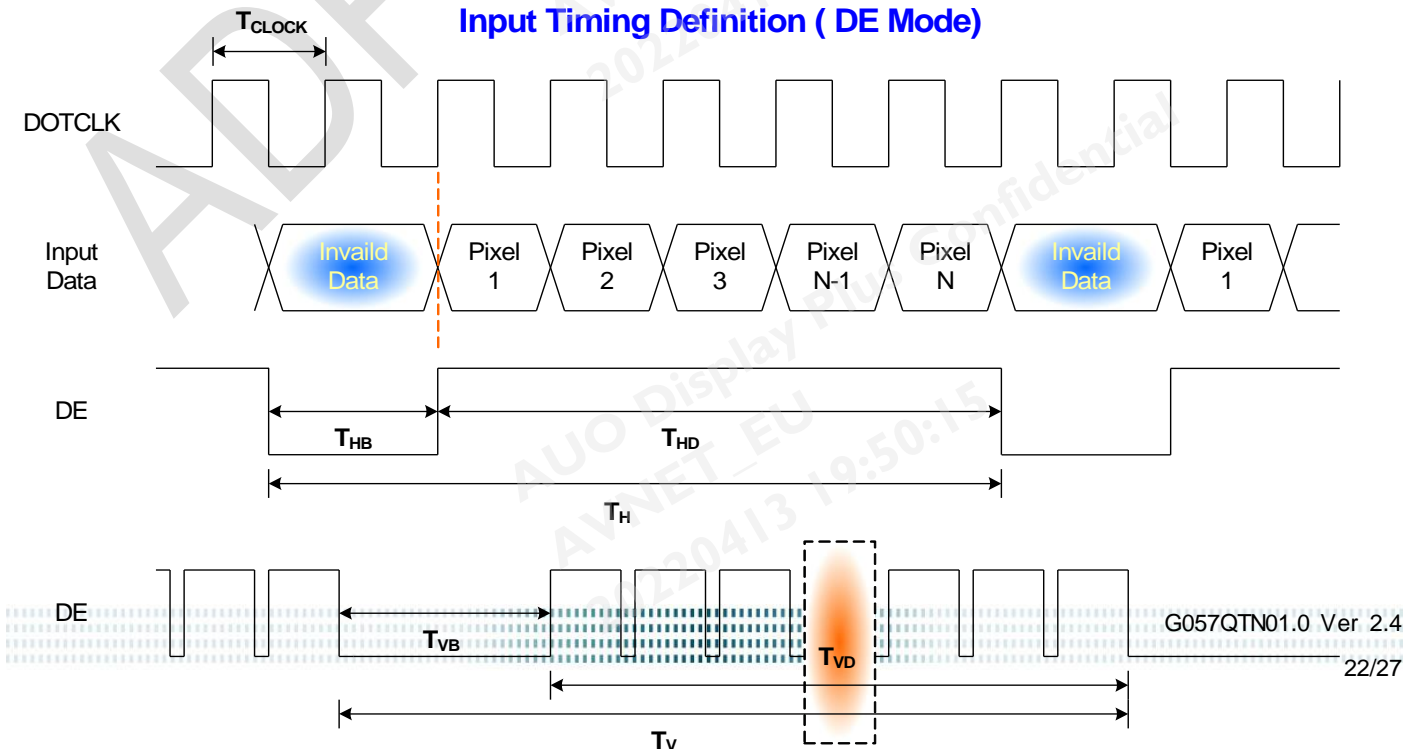

6.6 LED Backlight Unit Interface Signal Description

Pin #	Symbol	Pin Description
1	V _{LED}	12V input
2	V _{LED}	12V input
3	GND	Ground
4	GND	Ground
5	V _{PWM}	1~100% PWM dimming
6	V _{ENABLE}	0V-Off; 2~5V/NC-On

Note 1: "NC" stands for "No Connection"

6.7 Power ON/OFF Sequence

VDD power and LED on/off sequence is as below. Interface signals are also shown in the chart. Signals from any system shall be Hi-Z state or low level when VDD is off.

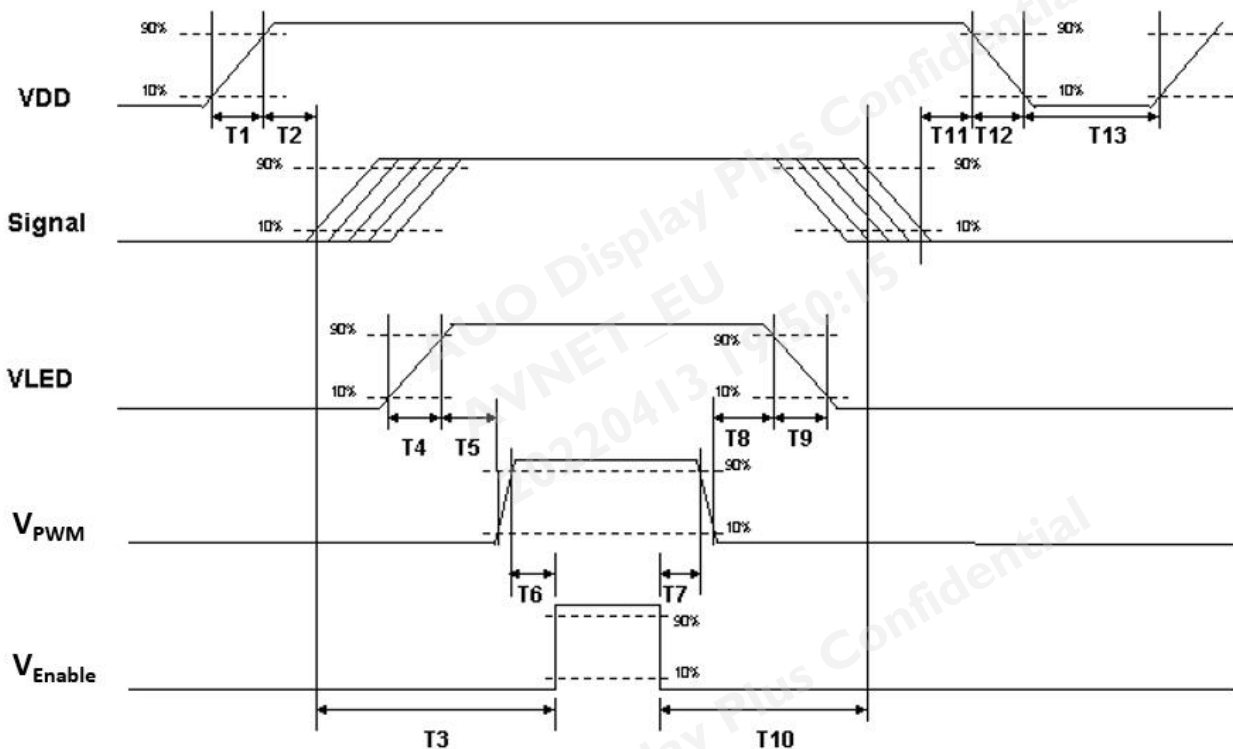

Power ON/OFF sequence timing

Parameter	Value			Units
	Min.	Typ.	Max.	
T1	0.5	-	10	[ms]
T2	30	40	50	[ms]
T3	200	-	-	[ms]
T4	0.5	-	10	[ms]
T5	10	-	-	[ms]
T6	10	-	-	[ms]
T7	0	-	-	[ms]
T8	10	-	-	[ms]
T9	-	-	10	[ms]
T10	110	-	-	[ms]
T11	0	16	50	[ms]
T12	-	-	10	[ms]
T13	1000	-	-	[ms]

The above on/off sequence should be applied to avoid abnormal function in the display. Please make sure to turn off the power when you plug the cable into the input connector or pull the cable out of the connector.

7. Connector & Pin Assignment

Physical interface is described as for the connector on module. These connectors are capable of accommodating the following signals and will be following components.

7.1 TFT- LCD Signal (CN1): LCD Connector

Manufacturer	Starconn
Connector Model Number	089H33-000100-G2-R, compatible with MS2406P33M

7.2 LED Backlight Unit (CN2): Backlight Connector

Manufacturer	JST
Connector Model Number	SM06B-SRKS-G-TB compatible with JST SM06B-SRSS-TB (LS) (SN)
Mating Connector Model Number	JST SHR-06V-BKHF-B or compatible

7.3 LED Light Bar Input (CN3): Light Bar Connector

Manufacturer	STM or compatible
Connector Model Number	P24021P6 or compatible
Mating Connector Model Number	SM06B-SHLK-G-TF or compatible

Pin #	Symbol	Pin Description	Cable color
1	AN1	Channel 1 LED anode	Red
2	AN2	Channel 2 LED anode	Red
3	AN3	Channel 3 LED anode	Red
4	CA1	Channel 1 LED cathode	White
5	CA2	Channel 2 LED cathode	Blue
6	CA3	Channel 3 LED cathode	Black

7.4 Connector Illustration

7.4.1 PIN 1 definition of CN1 and CN2

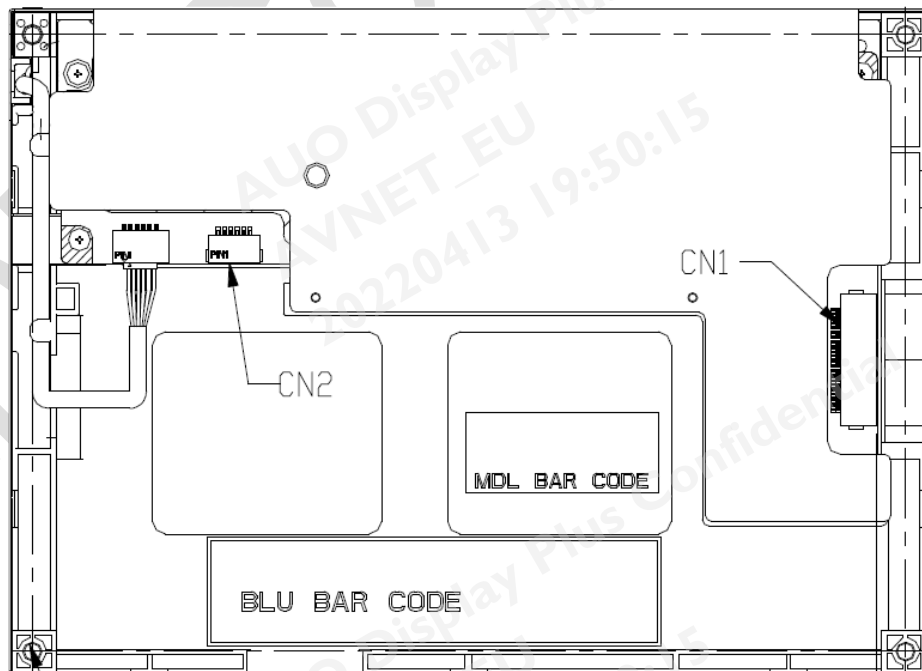

(Rear side of TFT-LCD)

7.4.2 PIN 1 definition of CN3

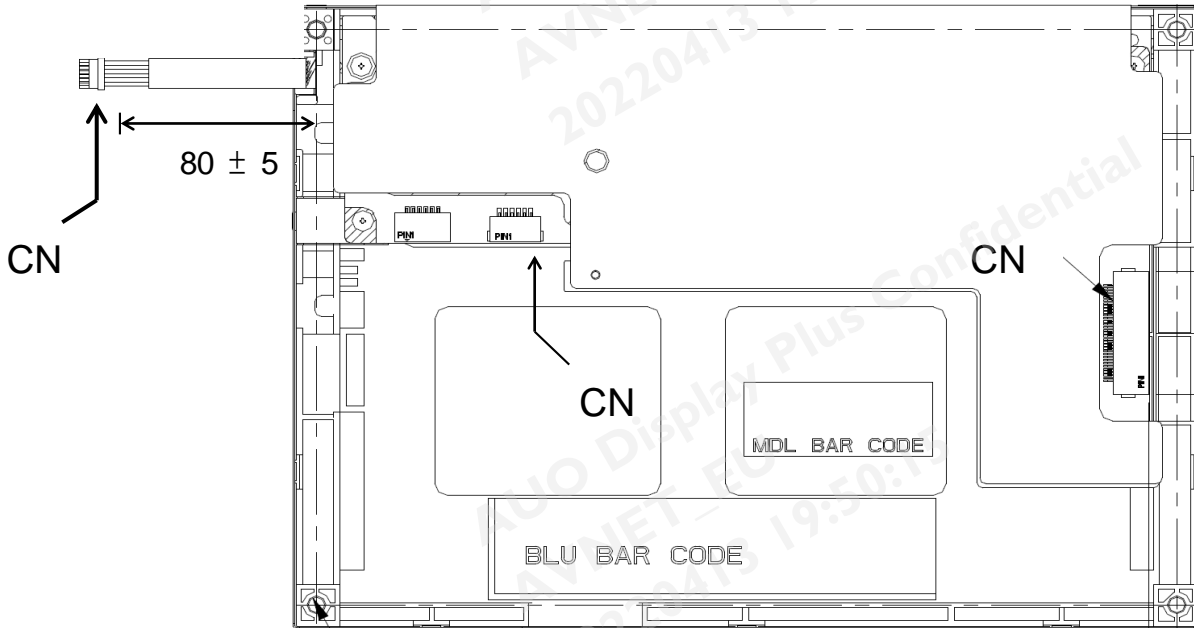

8. Reliability Test Criteria

Items	Required Condition	Note
Temperature Humidity Bias	40°C /90%,300 hours	Note 2
High Temperature Operation	85°C ,300 hours	Note 2
Low Temperature Operation	-30°C ,300 hours	Note 2
Hot Storage	85°C ,300 hours	Note 2
Cold Storage	-30°C ,300 hours	Note 2
Thermal Shock Test	-20°C /30 min ,60°C /30 min ,100cycles	Note 2
Hot Start Test	85°C /1 Hr (min.), power on/off per 5 minutes, repeat 5 times	Note 2
Cold Start Test	-30°C /1 Hr (min.), power on/off per 5 minutes, repeat 5 times	Note 2
Shock Test (Non-Operating)	50G,20ms,Half-sine wave,(±X, ±Y, ±Z)	Note 2
Vibration Test (Non-Operating)	1.5G, (10~200Hz, P-P) 30 mins/axis (X, Y, Z)	Note 2
On/off test	On/10 sec, Off/10 sec, 30,000 cycles	Note 1,2
ESD	Contact Discharge:±8KV,150pF(330Ω)1sec,8 points,25 times/ point Air Discharge: ±15KV, 150pF(330Ω)1sec, 8 points, 25 times/ point	Note 2
Altitude Test	Operating: 14,000 ft, Ramp: 2000 ft/min, 8hrs Non-operating: 40,000 ft, Ramp: 2000 ft/min, 24hrs	Note 2

Note 1: According to EN61000-4-2, ESD class B: Some performance degradation allowed. No data lost . Self-recoverable. No hardware failures.

Note 2:

- Water condensation is not allowed for each test items.
- Each test is done by new TFT-LCD module. Don't use the same TFT-LCD module repeatedly for reliability test.
- The reliability test is performed only to examine the TFT-LCD module capability.
- To inspect TFT-LCD module after reliability test, please store it at room temperature and room humidity for 24 hours at least in advance.
- No function failure occurs.

9. Mechanical Characteristics

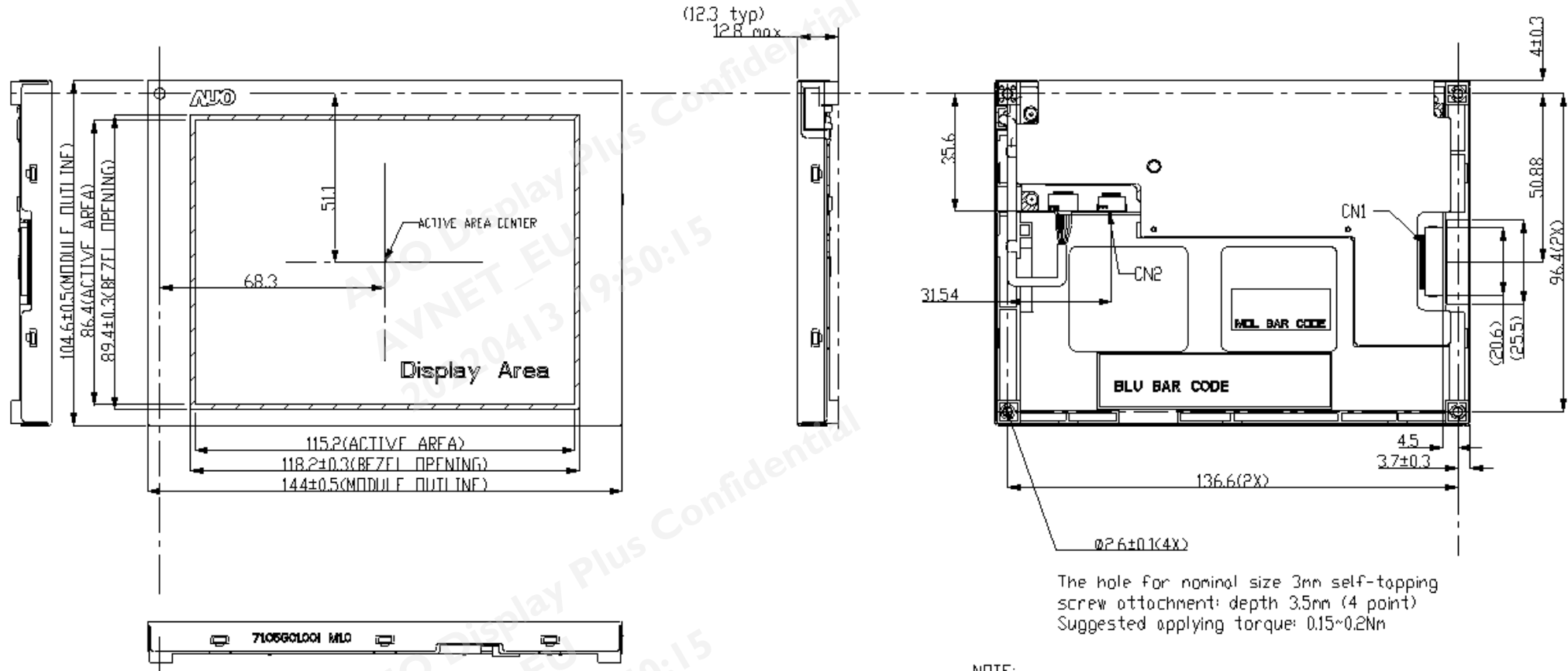

The hole for nominal size 3mm self-tapping screw attachment: depth 3.5mm (4 point)
Suggested applying torque: 0.15~0.2Nm

NOTE:
1. CN1: I/F CONNECTOR IS 089H33-000100-G2-R (STARCONN)
CN2: LED DRIVER CONNECTOR IS SM06B-SRKS(HF)(JST)
2. TOLERANCE IS ±0.5 IF NOT SPECIFIED.

10. Label and Packaging

10.1 Shipping Label (on the rear side of TFT-LCD display)

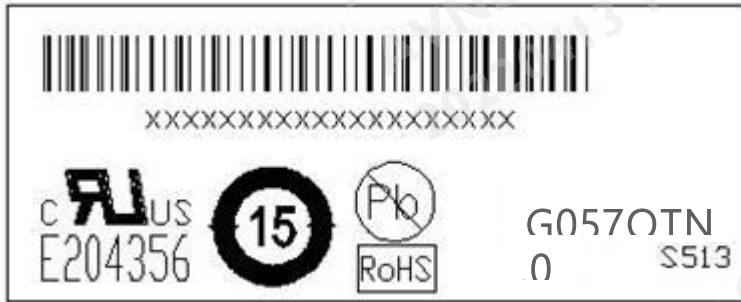

10.2 Carton Package

Max. capacity: 60 pieces TFT-LCD module per carton

Max. weight: 12.95 kg per carton

Outside dimension of carton: 520(L)mm* 340(W)mm* 250(H)mm

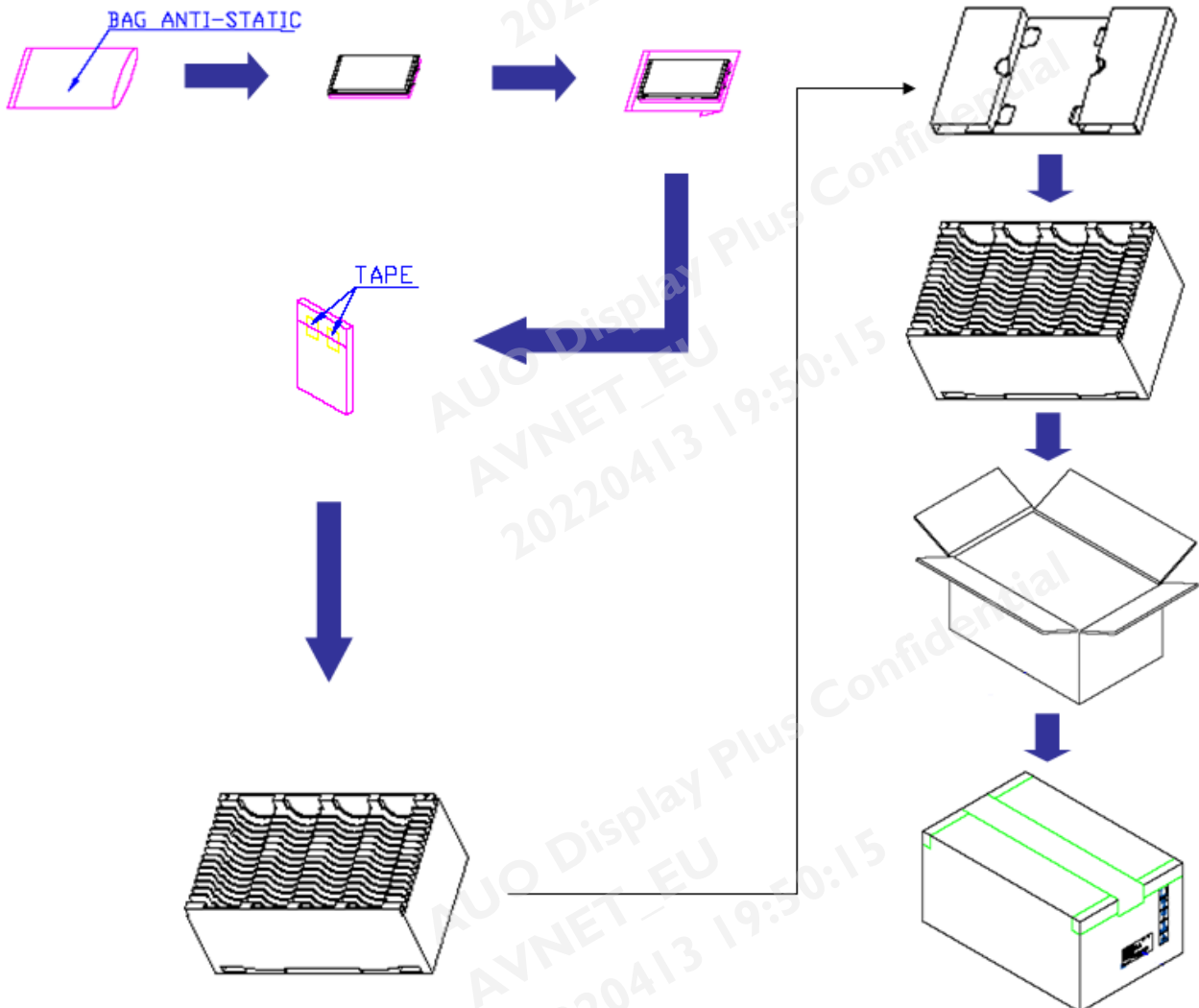

11 Safety

11.1 Sharp Edge Requirements

There will be no sharp edges or corners on the display assembly that could cause injury.

11.2 Materials

11.2.1 Toxicity

There will be no carcinogenic materials used anywhere in the display module. If toxic materials are used, they will be reviewed and approved by the responsible AUO toxicologist.

11.2.2 Flammability

All components including electrical components that do not meet the flammability grade UL94-V1 in the module will complete the flammability rating exception approval process.

The printed circuit board will be made from material rated 94-V1 or better. The actual UL flammability rating will be printed on the printed circuit board.

11.3 Capacitors

If any polarized capacitors are used in the display assembly, provisions will be made to keep them from being inserted backwards.

11.4 National Test Lab Requirement

The display module will satisfy all requirements for compliance to:

UL 60950-1, Second Edition

U.S.A. Information Technology Equipment